

US-DL9000 LABEL PRINTING SCALE

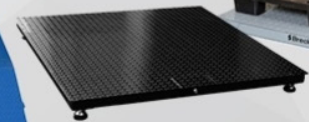

USA Measurements
"We Outmeasure the Competition"

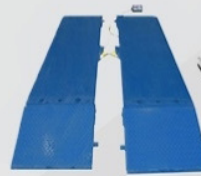

SPECIFICATIONS

- Dual Capacity Range
- 30 lb x .01 lb & 60 lb x .02 lb
- Resolution: 1/3,000(Dual Interval)
- Display Type: LCD, Dot Matrix LCD with Backlight
- Printing Speed (mm/sec): 95
- Operating Temp (F/C): 14 ~ 104/-10 ~ +40
- Power: AC 120V, 50/60Hz
- Platter Size (in/mm) (W x D): 14.3 x 11.1/364 x 281
- Dimensions (in/mm) (W x D x H): 15.4 x 17.3 x 21.2/391 x 439 x 541
- Product Weight (LB/KG): 25.5/11.5
- Shipping Weight (LB/KG): 28.5/12.9
- Warranty: 2 Year on Frame
- Warranty: 1 Year Electronics

DISPLAY

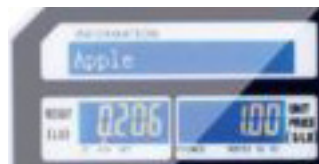

LABEL FORMATS



KEY LAYOUT



PRINT & LABEL CARTRIDGE



US-DL9000 LABEL PRINTING SCALE (ETHERNET, WIRELESS NETWORKING, & USB) NTEP APPROVED

USA Measurements **US-DL9000 Label Printing Scale**. Designed for businesses that require an easy to use scale, easily programmable, and reliable for years to come. The US-DL9000 can store up to 20,000 PLU's, is very easy to set-up, and includes our XDB software to program for your business. Great for supermarkets, deli's, farmers markets, speciality stores, and fish markets.



Unlike many other label printing scales on the market. Our US-DL9000 has everything packed into one scale. No need to upgrade down the road, replace, or buy software. This has everything you need. Dual range capacity: 30lb & 60lb, 20,000 PLU Including Ingredients Function, WiFi & Ethernet Connection, and 32 Standard Label Formats & 67 Customer Design Label Formats. This will fit all your needs for any business.

FEATURES

- 30lb/60lb Capacity Dual Capacity
- Standard: 20,000 PLU's include Ingredients
- 168 Speed Keys(56 keys x 3)
- 32 Standard Label Formats & 67 Custom Labels
- High Speed Thermal Printer
- USB & network for easy firmware upgrades
- Multiple barcode formats
- English, Chinese, Korean, or Spanish Characters
- Menu Code System
- XDB Software Package
- Included – PLU Editor – Label Editor – Keypad Editor
- Compatible with Microsoft Windows
- Ethernet, Wireless Networking, USB, RS-232C Built-in
- CLASS III – NTEP Approved (Legal for trade)

POLE MODEL

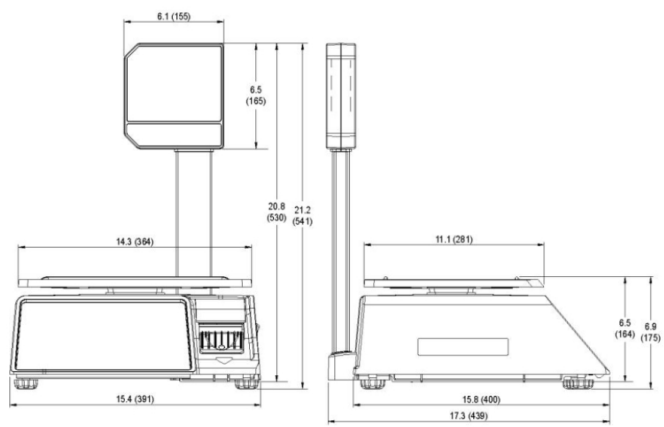

UNITS: INCHES (mm)

DIMENSIONS

